



S
N
S
N
S

NON STANDARD
METRIC PITCH CHAINS



NON STANDARD METRIC PITCH CHAINS

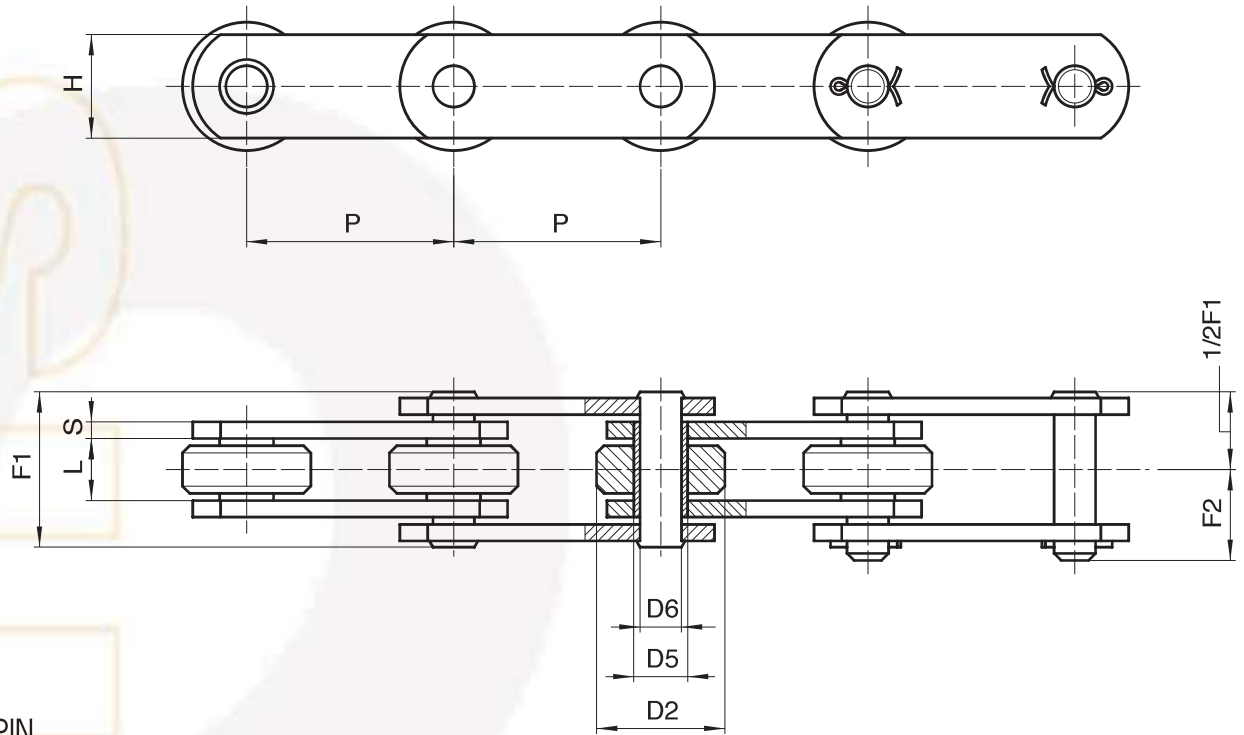

SOLID PIN CHAINS

Chain N.	P mm	L mm	D2 mm	D5 mm	D6 mm	H mm	S mm	F1 mm	F2 mm	Breaking load N	Chain weight kg/m
103	50	11,5	25	8,4	5,7	15	2	24	14,6	16.000	1,4
200	50	11,5	25	8,4	5,7	15	3	28	16,5	18.000	1,7
202	69	11,5	25	8,4	5,7	15	3	28	16,5	18.000	1,5
203	75	11,5	25	8,4	5,7	20	3	28	16,5	18.000	1,7
205	50	11,5	25	8,4	5,7	18	2,5	26	16	18.000	1,7
205SS*	50	11,5	25	8,4	5,7	18	2,5	26	16	18.000	1,7
206	50	11,5	25	11	8	20	3	28	17	30.000	1,9
206SS*	50	11,5	25	11	8	20	3	28	17	22.000	1,9
206R	50	11,5	25	11	8	20	3	28	17	45.000	1,9

(*) STAINLESS steel chain

Additional features:

- rollers of nylon, delrin, etc.
- surface treatments of zinc plating, nickel plating, etc.
- with extended pins
- pre-tensioned and labelled



NON STANDARD METRIC PITCH CHAINS

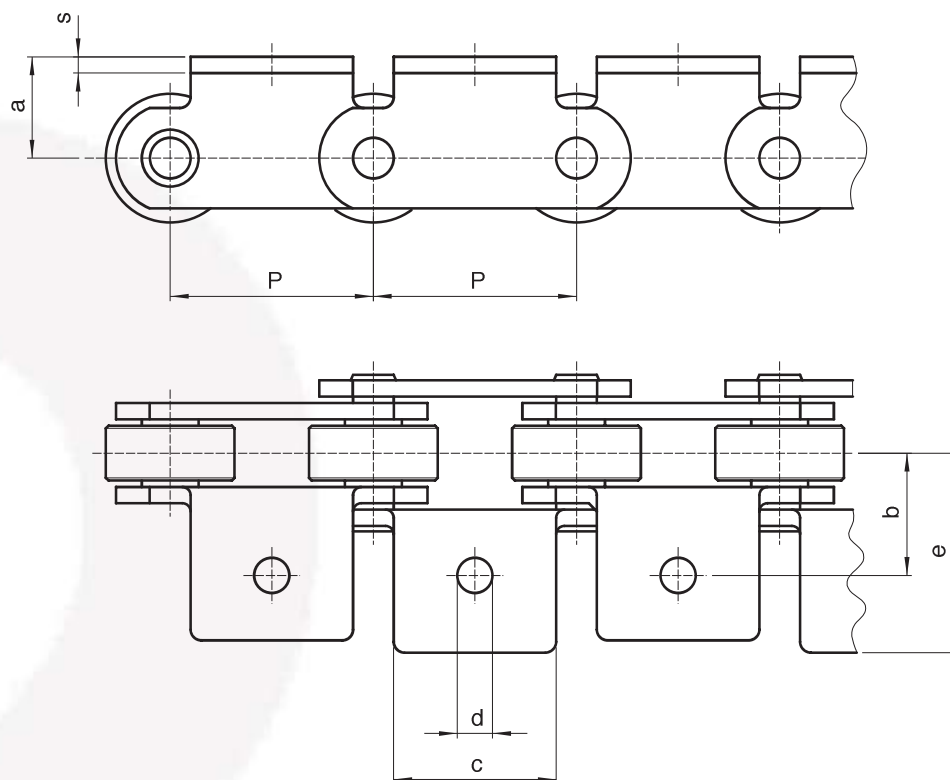

Layout of attachments
on page 1.9/2

ATTACHMENTS

Chain N.	P mm	a mm	b mm	c mm	d mm	e mm	s mm	Weight per attach. kg
103	50	25	21	41	6,5	32	2	0,023
200	50	25	24	41	6,5	34	3	0,035
202	69	27	24	66	6,5	34	3	0,050
203**	75	27	33	46	6,5	46	3	0,055
205	50	24	22	46	6,5	36	2,5	0,035
205B	50	14	32	46	6,5	45	2,5	0,035
205SS	50	24	22	46	6,5	36	2,5	0,035
206	50	24	23	40	6,5	38	3	0,035
206SS	50	24	23	40	6,5	38	3	0,035
206R	50	24	23	40	6,5	38	3	0,035

(**) Chain supplied only with attachments A101/A102



NON STANDARD METRIC PITCH CHAINS

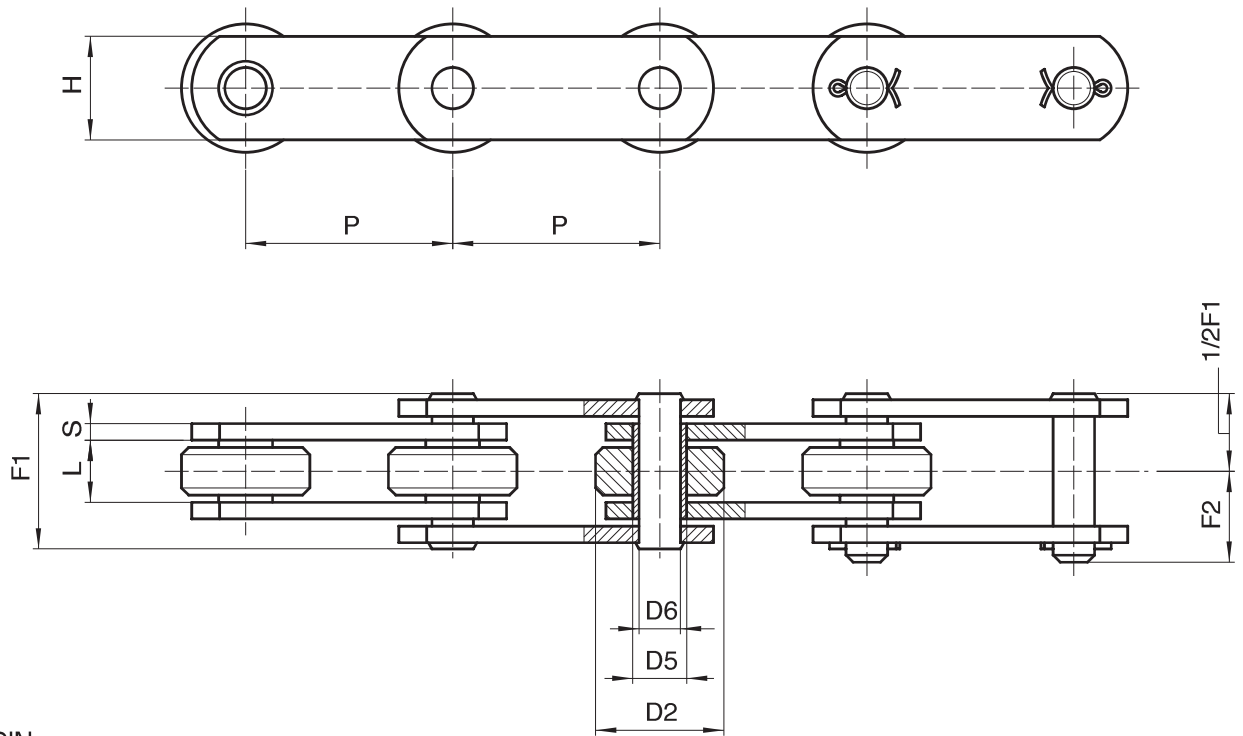

SOLID PIN CHAINS

Chain N.	P mm	L mm	D2 mm	D5 mm	D6 mm	H mm	S mm	F1 mm	F2 mm	Breaking load N	Chain weight kg/m
400**	50	15	31	13,2	10	23	3	33	19,5	35.000	3
400SS*	50	15	31	13,2	10	23	3	33	19,5	30.000	3
401	75	15	31	13,2	10	25	3	33	19,5	35.000	2,8
402	100	15	31	13,2	10	25	3	33	19,5	35.000	2,3
500	50	15	31	13,2	10	25	4	36	21	45.000	3,9
500R***	50	15	31	13,2	10	25	4	36	21	75.000	3,9
500BR	50	15	31	13,2	10	25	4	36	21	75.000	3,9
501	75	15	31	13,2	10	25	4	36	21	45.000	3,2
502	100	15	31	13,2	10	25	4	36	21	45.000	2,7
5021432	100	15	31	13,2	10	25	4	36	21	75.000	2,7
503	125	15	31	13,2	10	25	4	36	21	45.000	2,5
504	150	15	31	13,2	10	25	4	36	21	45.000	2,4
701	75	22	40	17	12	35	4	43	25	75.000	5,9
703	100	22	40	17	12	35	4	43	25	75.000	4,9
W1743	100	24	40	17	12	35	4	45	26	75.000	6,3
704	125	22	40	17	12	35	4	43	25	75.000	4,4
705	150	22	40	17	12	35	4	43	25	75.000	4

(*) STAINLESS steel chain
 (**) Chain with shaped plates
 (***) Attachment dimensions as chain type 500

- Additional features:
- rollers of nylon, delrin, etc.
 - surface treatments of zinc plating, nickel plating, etc.
 - bush chain (without roller)
 - with extended pins
 - pre-tensioned and labelled

NON STANDARD METRIC PITCH CHAINS

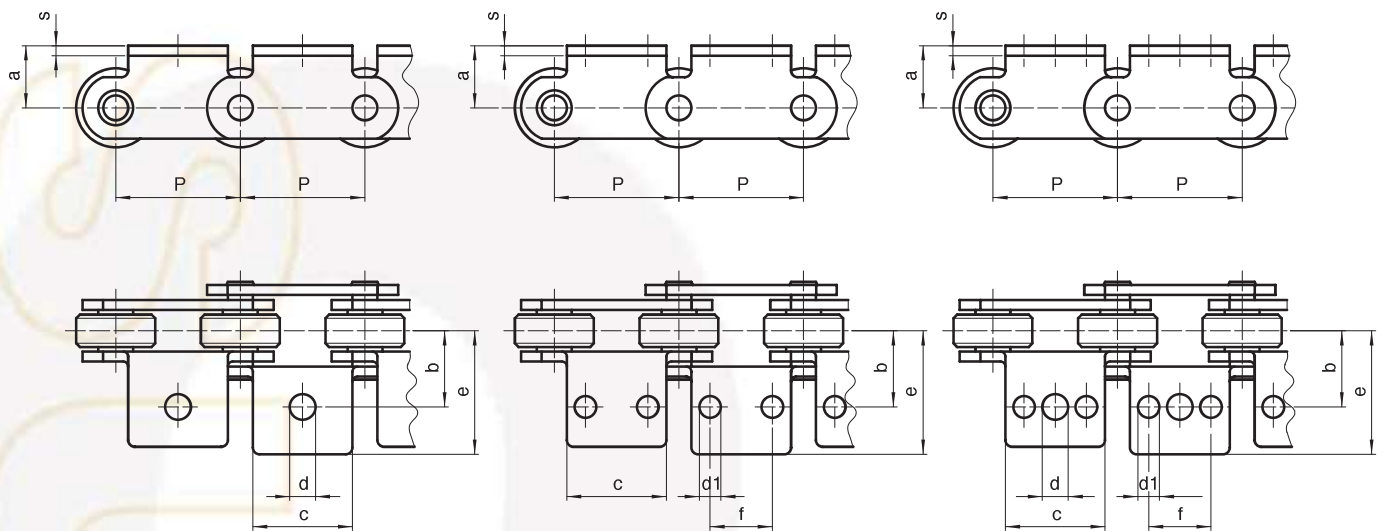

Layout of attachments
on page 1.9/2

ATTACHMENTS

Chain N.	Attachments assembly	P mm	a mm	b mm	c mm	d mm	d1 mm	e mm	f mm	s mm	Weight per attach. kg
400	only on outer links	50	35	31	60	10	8,5	48,5	25	3	0,080
400	all	50	28	31	30	10	/	46	/	3	0,035
400B	all	50	16,5	42	30	10	/	57	/	3	0,035
400B	only on outer links	50	16,5	31	60	10	8,5	48,5	25	3	0,050
400SS	all	50	28	31	30	10	/	46	/	3	0,035
400SS	only on outer links	50	35	31	60	10	8,5	48,5	25	3	0,080
401 ● ♣	all	75	30	28	60	10	9	41,5	30	3	0,060
402 □	all	100	35	31	70	10	9	46,5	35	3	0,085
500/500R ● ♣	all	50	35	32	45	10	8,5	48,5	25	4	0,070
500B ● ♣	all	50	22	45	45	10	8,5	61,5	25	4	0,070
500BR ● ♣	only on outer links	50	17,5	34	60	10	9	50	30	4	0,070
501 □	all	75	30	29	60	10	9	44,5	30	4	0,080
502 □	all	100	35	32	70	10	9	48,5	35	4	0,100
5021432 □	all	100	-1,5	30 ■	60	9	6,5	46	40	4	0,025
503 □	all	125	35	32	70	10	9	56	35	4	0,160
504 ♣	all	150	35	32	100	10	9	56	50	4	0,250
701 ♣	all	75	26	38	50	10	9	73	25	4	0,100
703 □	all	100	40	38	70	10	9	58	35	4	0,140
703B □	all	100	26	38	70	10	9	73	35	4	0,120
W1743 ●	all	100	26	38	70	16,5	/	73	35	4	0,140
704 ♣	all	125	26	40	100	10	9	62,5	70	4	0,150
705 ♣	all	150	26	40	100	10	9	56,5	50	4	0,180

- attachments with 1 hole
- ♣ attachments with 2 holes
- attachments with 3 holes
- central hole: b=32,5



NON STANDARD METRIC PITCH CHAINS

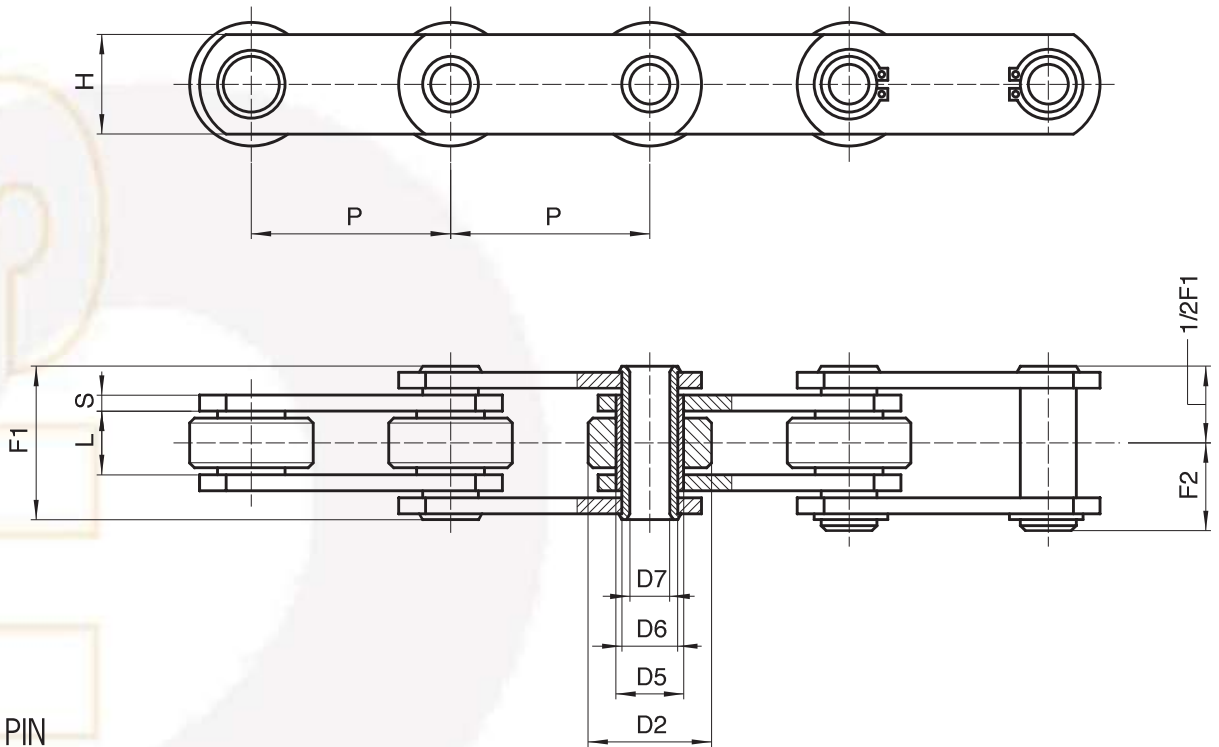

HOLLOW PIN CHAINS

Chain N.	P mm	L mm	D2 mm	D5 mm	D6 mm	D7 mm	H mm	S mm	F1 mm	F2 mm	Breaking load N	Chain weight kg/m
250	50	11,5	25	11	9	6,2	20	2,5	25	14	25.000	1,8
250R	50	11,5	25	11	9	6,2	20	2,5	25	14	38.000	1,8
250SS*	50	11,5	25	11	9	6,2	20	2,5	25	14	22.000	1,8
400C**	50	15	31	17	14	10,2	25	3	31	17	35.000	3
W3635	50	15	31	17	14	10,2	25	3	31	17	35.000	3
500C	50	15	31	17	14	10,2	25	4	35	18,5	40.000	3,6
500CRP***	50	15	31	17	14	10,2	25	4	35	18,5	65.000	3,6
500CSS*	50	15	31	17	14	10,2	25	4	35	20	40.000	3,6
501C	75	15	31	17	14	10,2	25	4	35	18,5	40.000	3,1
501CSS*	75	15	31	17	14	10,2	25	4	35	20	40.000	3,1
502C	100	15	31	17	14	10,2	25	4	35	18,5	40.000	2,6
502CSS*	100	15	31	17	14	10,2	25	4	35	20	40.000	2,6
503C	125	15	31	17	14	10,2	25	4	35	18,5	40.000	2,4
503CSS*	125	15	31	17	14	10,2	25	4	35	20	40.000	2,4
504C	150	15	31	17	14	10,2	25	4	35	18,5	40.000	2,3
701C	75	22	40	23	18	12,2	35	4	45	23,5	60.000	5,4
703C	100	22	40	23	18	12,2	35	4	45	23,5	60.000	4,4
703CR	100	22	40	23	18	12,2	35	4	45	23,5	75.000	4,4
704C	125	22	40	23	18	12,2	35	4	45	23,5	60.000	4,2
704CR	125	22	40	23	18	12,2	35	4	45	23,5	75.000	4,2
705C	150	22	40	23	18	12,2	35	4	45	23,5	60.000	4
705CR	150	22	40	23	18	12,2	35	4	45	23,5	75.000	4

(*) STAINLESS steel chain
 (**) Chain with shaped plates
 (***) Pre-tensioned and labelled

Additional features:
 - rollers of nylon, delrin, etc.
 - surface treatments of zinc plating, nickel plating, etc.
 - bush chain (without roller)
 - pre-tensioned and labelled



NON STANDARD METRIC PITCH CHAINS

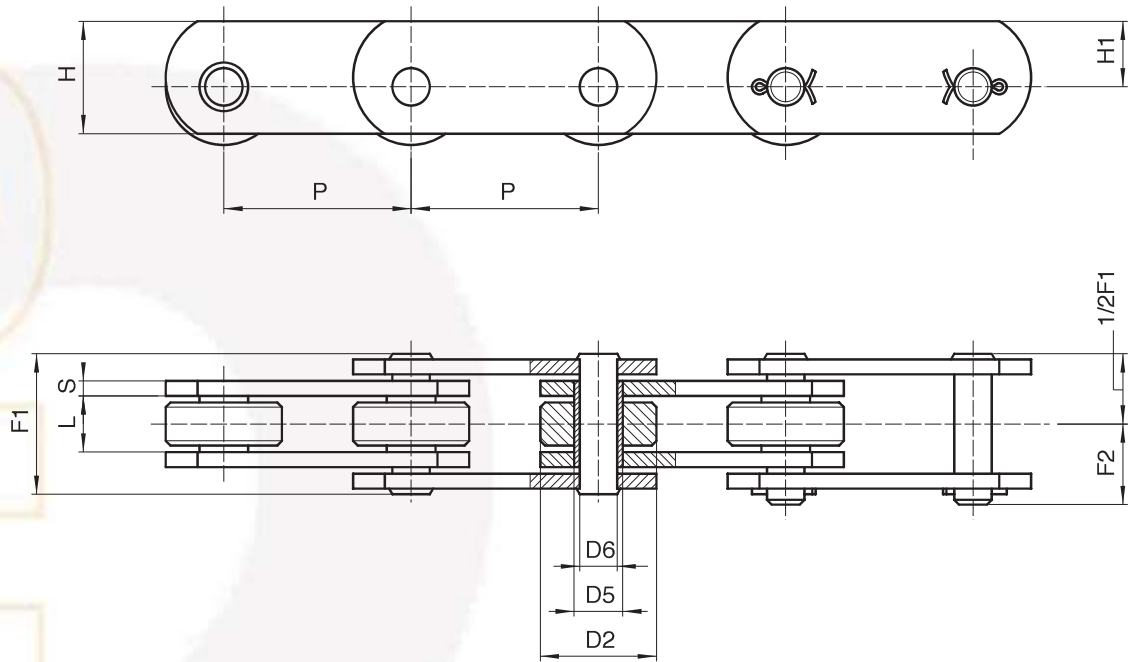

DEEP LINK CHAINS

Chain N.	P mm	L mm	D2 mm	D5 mm	D6 mm	H mm	H1 mm	S mm	F1 mm	F2 mm	Breaking load N	Chain weight kg/m
350Z**	50	11,5	18	8,4	5,7	17,5	10	2,5	25,5	15,5	18.000	1,25
351	50	11,5	25	8,4	5,7	25	16,5	2	24	15	16.000	2
352	50	15	31	13,2	10	30	17,5	4	36	21	55.000	4,5
352SS*	50	15	31	13,2	10	30	17,5	4	36	21	45.000	4,5
353	75	15	31	13,2	10	30	17,5	4	36	21	55.000	3,8
353SS*	75	15	31	13,2	10	30	17,5	4	36	21	45.000	3,8
354	100	15	31	13,2	10	30	17,5	4	36	21	55.000	3,5
354SS*	100	15	31	13,2	10	30	17,5	4	36	21	45.000	3,5

(*) STAINLESS steel chain
 (**) Zinc plated chain

Additional features:
 - rollers of nylon, delrin, etc.
 - surface treatments of zinc plating, nickel plating, etc.
 - pre-tensioned and labelled



NON STANDARD CHAINS

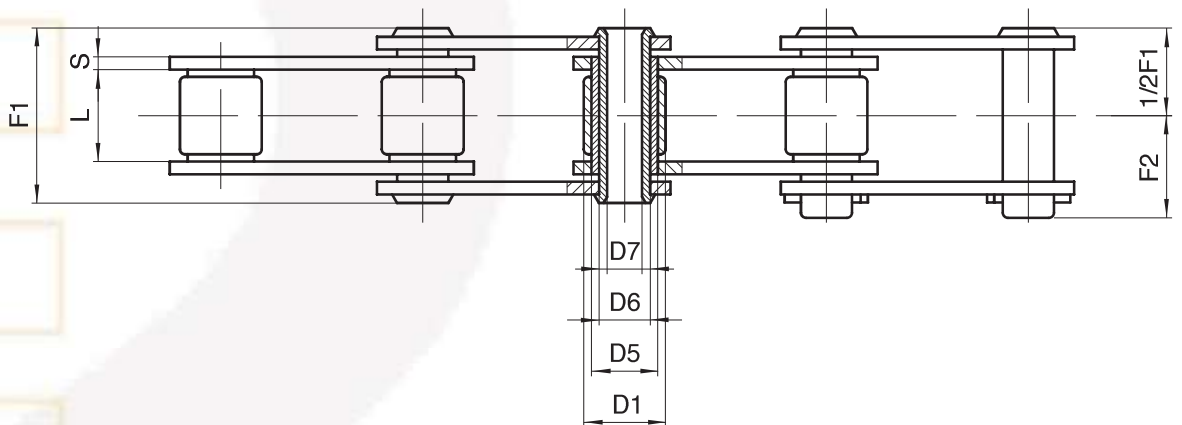
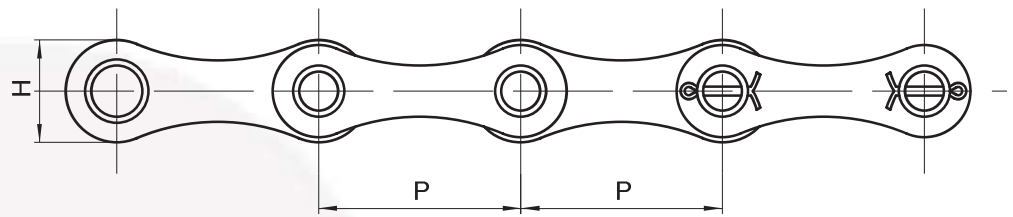

HOLLOW PIN CHAINS

Chain N.	P mm	L mm	D1 mm	D5 mm	D6 mm	D7 mm	H mm	S mm	F1 mm	F2 mm	Breaking load N	Chain weight kg/m
260	41,75	20,5	17	13,8	11	8,3	22	3	36	22,7	27.000	1,5
260SS*	41,75	20,5	17	13,8	11	8,3	22	3	36	22,7	13.500	1,5
260RZ**	41,75	20,5	17	13,8	11	8,3	25	3	36	22,7	35.000	1,9
260RBZ**	41,75	20,5	17	13,8	11	8,3	25	3	36	22,7	50.000	1,9

(*) STAINLESS steel chain
 (**) Zinc plated chain

Additional features:
 - rollers of nylon, delrin, etc.
 - surface treatments of zinc plating, nickel plating, etc.
 - pre-tensioned and labelled



NON STANDARD CHAINS

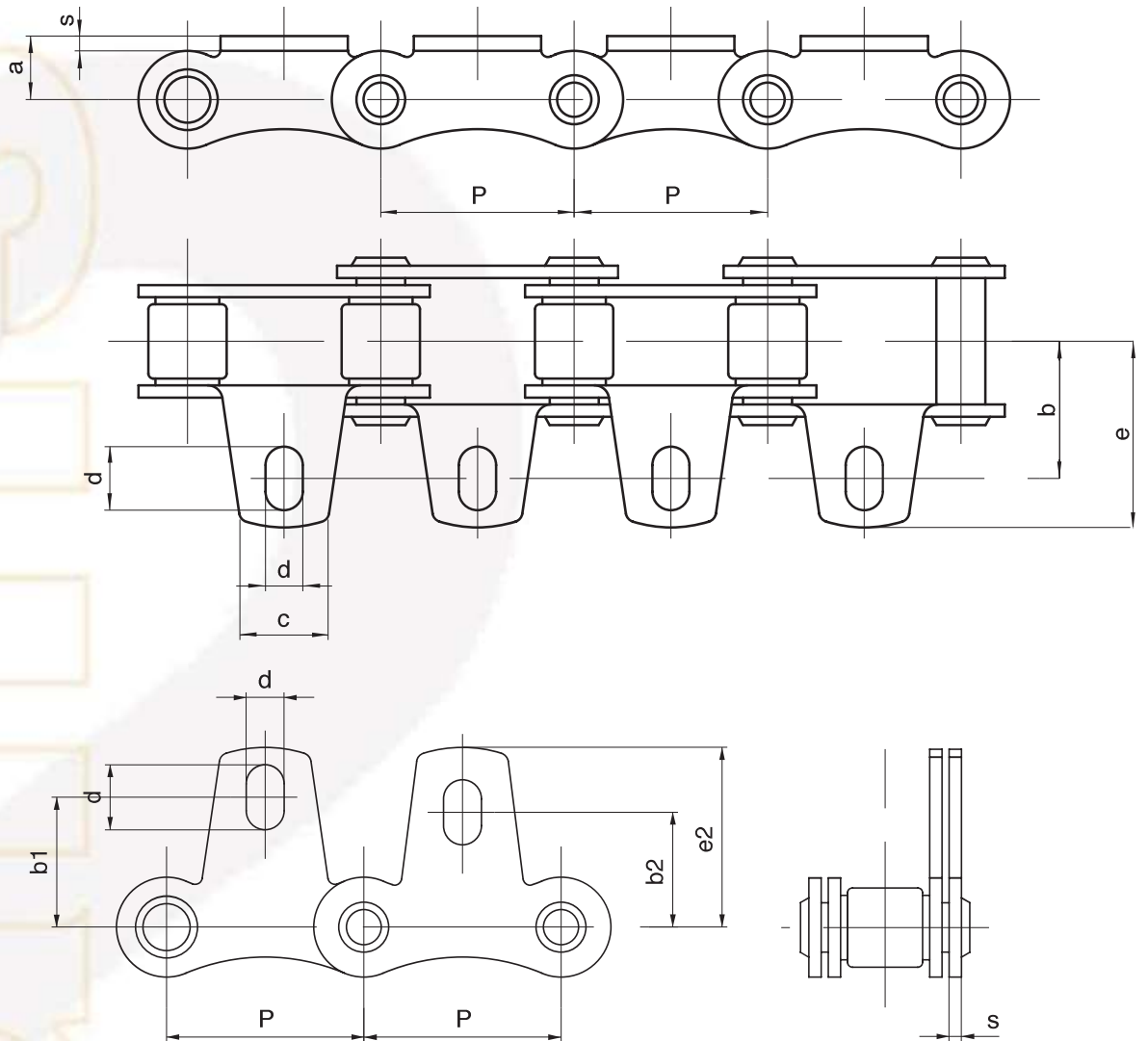

ATTACHMENTS

Chain N.	P mm	a mm	b mm	b1 mm	b2 mm	c mm	d mm	e mm	e1 mm	s mm	Weight per attach. kg
260	41,75	13,5	30	29	25	19	14-8,3	43,5	39,5	3	0,020
260SS	41,75	13,5	30	29	25	19	14-8,3	43,5	39,5	3	0,020



NON STANDARD CHAINS

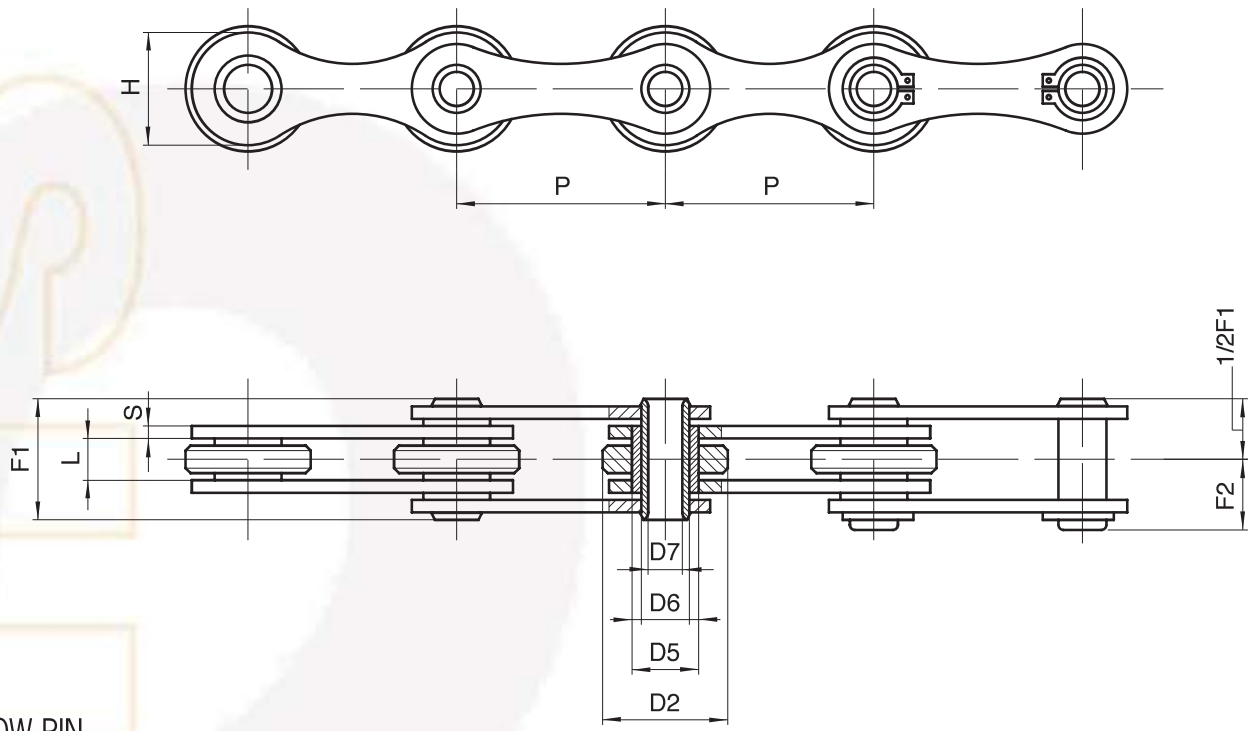

HOLLOW PIN CHAINS

Chain N.	P mm	L mm	D2 mm	D5 mm	D6 mm	D7 mm	H mm	S mm	F1 mm	F2 mm	Breaking load N	Chain weight kg/m
261	50	10	30	16	11,5	8,2	25,5	3	26,5	14,5	60.000	2,2
262	50,8	10	30	16	11,5	8,2	25,5	3	26,5	14,5	60.000	2,1
262SS*	50,8	10	30	16	11,5	8,2	25,5	3	26,5	14,5	32.000	2,1
W3865AR	60	10	30	16	11,5	8,2	26	3	26,5	14,5	60.000	1,5
W3604R	63	10	30	16	11,5	8,2	26	3	26,5	14,5	60.000	2,3
263	100	10	30	16	11,5	8,2	25,5	3	26,5	14,5	60.000	1,5

(*) STAINLESS steel chain

- Additional features:
- rollers of nylon, delrin, etc.
 - surface treatments of zinc plating, nickel plating, etc.
 - pre-tensioned and labelled

